

## Repair Parts

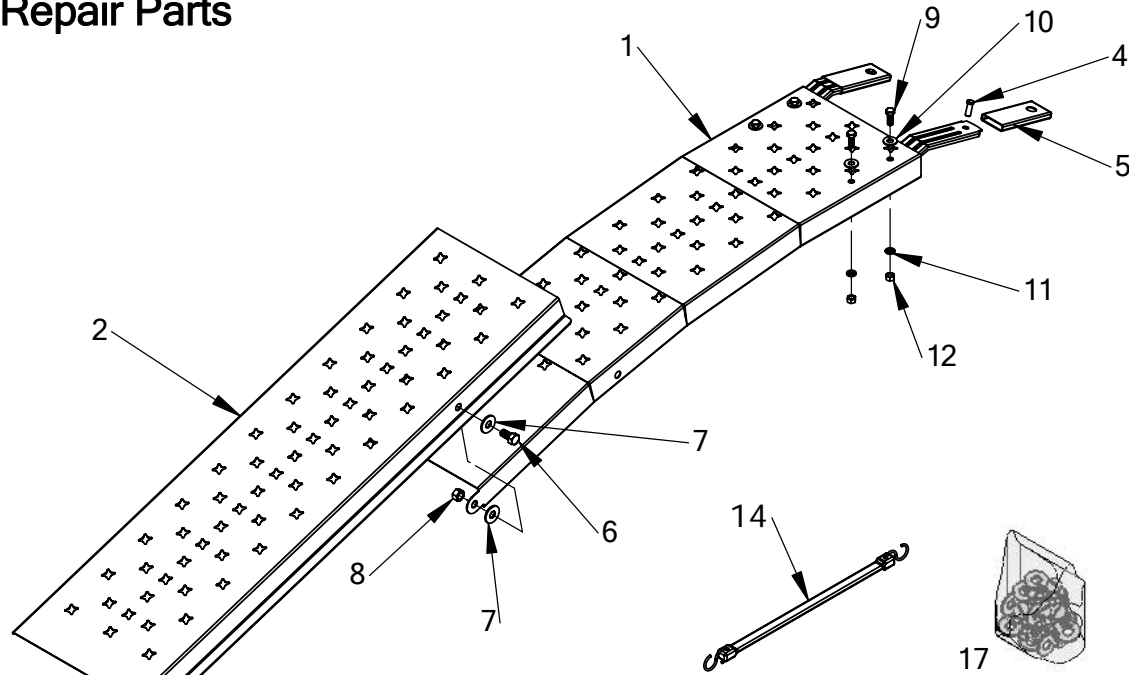

REF. NO.	PART NO.	AMT.	DESCRIPTION	REF. NO.	PART NO.	AMT.	DESCRIPTION
1	LR-01	2	RAMP TOP	9	STDBH375750	8	3/8\"-16 X 3/4\" BOLT
2	LR-02	2	RAMP BOTTOM	10	STDWF375	8	3/8\" FLAT WASHER
3	LR-03	4	SUPPORT BAR	11	STDWSL375	8	3/8\" LOCKWASHER
4	LR-04	4	CLEVIS PIN	12	STDNH375	8	3/8\"-16 HEX NUT
5	LR-05	4	SUPPORT BAR PADS	14	LR-14	2	BUNGEE W/S-HOOK
6	STDBH5001000	4	1/2\"-13 x 1\" BOLT	16	LR-16	1	MANUAL - NOT SHOWN
7	STDWF500	8	1/2\" FLAT WASHER	17	LR-17	1	HARDWARE BAG -
8	STDNC500	4	1/2\"-13 LOCKNUT	18	LR-18	1	WARNING DECAL - ON RAMP

REV-B

## LIMITED ONE-YEAR WARRANTY

If this product fails due to a defect in material or workmanship within one year from the date of purchase, Ohio Steel will at its option repair or replace it free of charge. **Proof of purchase required for all warranty claims.**

This warranty does not cover:

- Repairs necessary because of operator abuse or negligence.
- Equipment used for commercial or rental purposes.

Contact Ohio Steel to arrange for product repair, or return this product to place of purchase for replacement.

This warranty gives you specific legal rights, and you may also have other rights which vary from state to state. This Warranty applies only while this product is in use in the United States.

When ordering repair parts always give the following information, PRODUCT NAME, MODEL NUMBER, PART NUMBER, and PART DESCRIPTION.

# OHIO STEEL INDUSTRIES

## 14 GAUGE STEEL FOLDING LOADING RAMP

Model 1084

- 1000lbs capacity - single.
- 2000lbs capacity - double.
- Compact storage.
- One person loading.

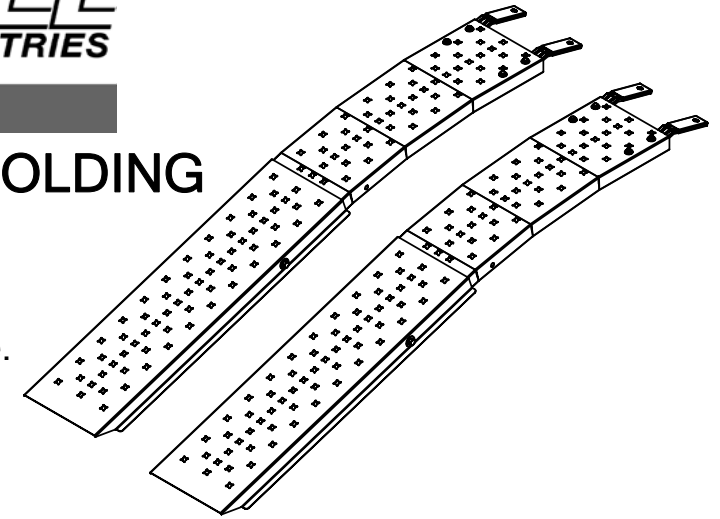

Manufactured under U.S. Patent No. 5,645,394

## WARNINGS

- The loading ramp surfaces are sharp. Always wear proper clothing and use care when handling the loading ramps. (Gloves are strongly recommended).
- Read and understand all safety and operating instructions before using the loading ramp. **Never** allow anyone unfamiliar with these instructions to use the loading ramps.
- Read and understand all safety and operating instructions provided by the manufacturer of the equipment the loading ramp will be used with.
- Extreme caution should always be used while loading and unloading your equipment.
- **Do not** exceed the rated capacity of the loading ramp.
- **Do not** exceed the rated capacity of the loading surface (i.e. tailgate). If unknown, contact the manufacturer to find the maximum load capacity.
- Never stand in the path of equipment being loaded, and keep all bystanders and children away from loading ramps.
- This ramp must be only used for loading and unloading to and from a level and stable surface.
- Use caution when using ramp in icy or wet conditions. The ramp surface may become slippery.
- **Do not** use this loading ramp to load live animals.
- **Do not** use loading ramps as a bridge, scaffolding, or any other use for which it is not intended or designed.
- If ramp is bowing while loading or unloading your equipment, which indicates an overload condition, remove the equipment immediately.
- **Do not** attempt to load or unload any power equipment with its motor running.
- Failure to follow these warnings may result in property damage and/or serious bodily injury.

Ohio Steel Industries  
Columbus, OH 43224 U.S.A.  
Visit our website: [www.ohiosteel.com](http://www.ohiosteel.com)

For missing parts or questions  
Call 1-800-652-2321

## SAFETY

- Be sure to read and follow all safety instructions and warnings. Failure to follow these instructions may result in damage to the product and/or serious personal injury.
- Danger of serious personal injury exists. Serious personal injury can occur when using a loading ramp.
- **Never** attempt to ride any vehicle up or down the loading ramp.
- Look for a wall or a depression to reduce the loading angle, the lower the ramp angle the easier the loading of the vehicle will be.
- Park the vehicle on flat, firm, grassy terrain.
- Set the emergency brake and chock the tires of the loading vehicle to prevent any movement while loading and unloading the equipment.
- Center loading ramp on the loading surface with support bars on top of the loading surface.
- Make sure ramps are aligned at the proper distance apart so that the tires of the equipment being loaded are centered on the ramp.
- To prevent kick back, always attach bungee straps between the bumper of the truck and the center of loading ramp, stretching strap at least 5 or 6 inches.
- Roll or winch equipment up or down the ramp.
- Before each use, always check for any worn, loose, or damaged parts on the loading ramp. If any damage is present, **DO NOT USE THE RAMP**.
- Periodically check the fasteners to make sure they are still tight and in place.
- Keep ramp surface clean by occasionally cleaning with water and any mild detergent.
- Do not add to or try to modify the loading ramp in any way. Any modifications will void any warranties as well as affect the structural integrity of the ramp itself.

## OPERATION

We suggest that you drill 7/16" diameter holes through the support bars (3) into the tail gate or truck bed so that the pins can be inserted as a safety device in holding ramps in place. To prevent kick back of the loading ramp, always attach bungee strap to bumper of truck and center of ramp stretching 5" to 6". Align individual ramps to correctly correspond to your ATV's track. Always remove key, turn fuel off, and set parking brake after loading ATV.

## TOOLS SUGGESTED FOR ASSEMBLY

- 7/16" wrench and/or socket
- 9/16" wrench and/or socket
- Large blade screwdriver

## Ramp Top Assembly

Step 1. Attach support bars (3) to ramp top (1) with bolts (9), flat washers (10), lock washers (11), and hex nuts (12). Tighten bolts at this time.

Step 2. Slide support bar pads (5) onto bars as shown.

Note: Apply a little soapy water inside support bar pad, this allows the pad to slide onto the bar easier.

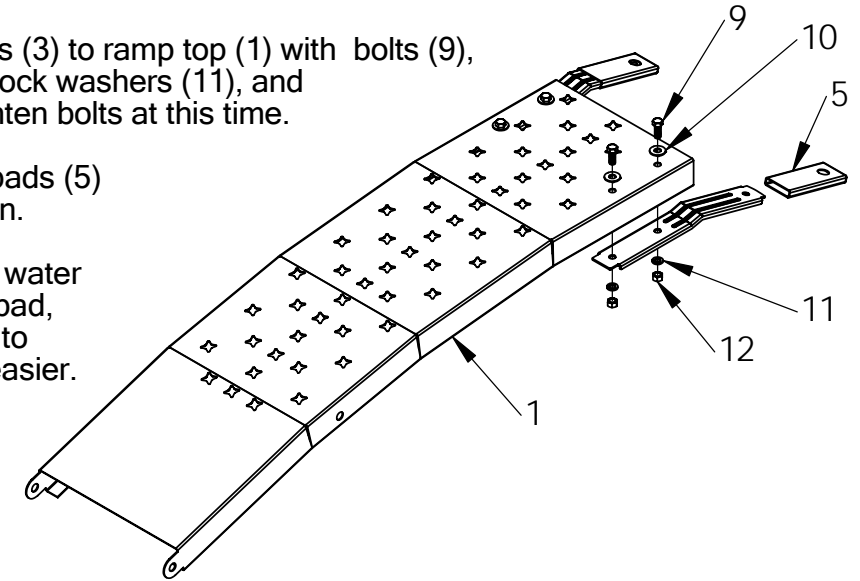

## Connecting the Two Ramp Halves

Step 3. Invert ramp bottom (2) so that flanges face up. Place ramp top (1) inside the ramp bottom so that the side holes of each are in line.

Step 4. Secure both side by inserting hex bolt (6) through flat washer (7), ramp top, flat washer (7), ramp bottom and tighten with lock nut (8) as shown.

NOTE: DO NOT OVER TIGHTEN. Ramp must be able to swivel open and shut.

