

36HW
REPAIR PART LIST

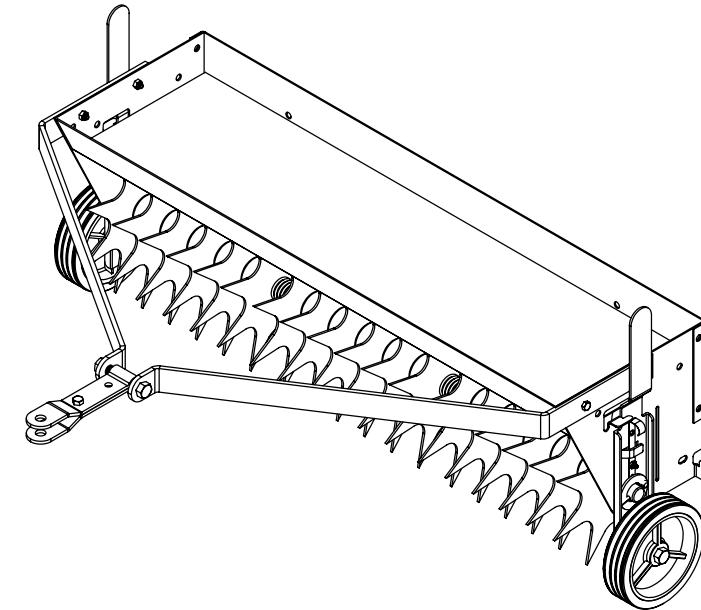

36HW
36" SPIKE AERATOR
ASSEMBLY MANUAL

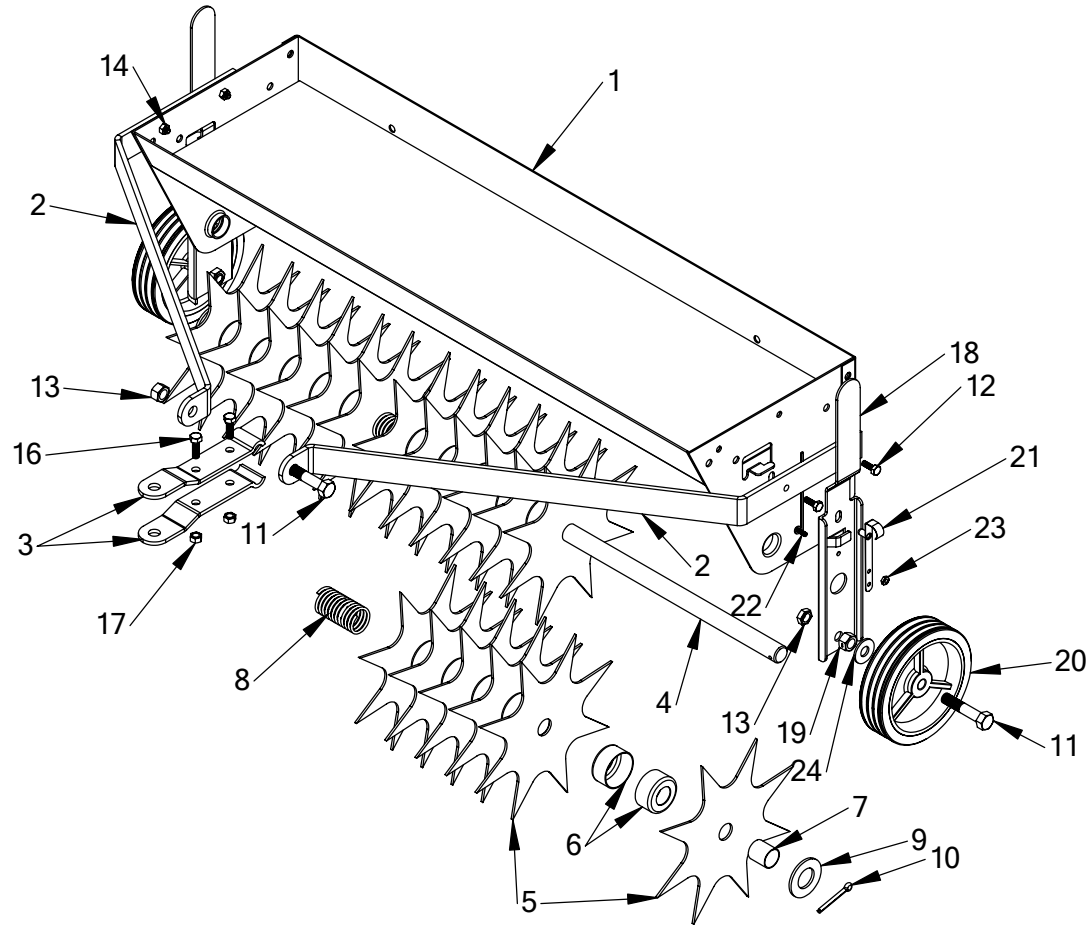

CAUTION:
READ AND FOLLOW
ALL SAFETY RULES
AND INSTRUCTIONS
BEFORE USING
THIS EQUIPMENT

Ohio Steel Industries
Columbus, OH 43224 U.S.A.
Visit our website: www.ohiosteel.com

For missing parts or questions
Call 1-800-652-2321

| REF.NO. | PART NO. | AMT. | DESCRIPTION | REF.NO. | PART NO. | AMT. | DESCRIPTION |
|---------|-----------|------|--------------------|---------|-----------|------|-------------------|
| 1 | 71-01 | 1 | Weight Tray | 13 | STD522450 | 3 | Lock Nut 1/2" |
| 2 | 71-02 | 2 | Side Bar | 14 | STD541425 | 4 | Lock Nut 1/4" |
| 3 | 71-03 | 2 | Hitch | 15 | 71-15 | 1 | Owners Manual |
| 4 | 71-04 | 1 | Axle | 16 | STD523110 | 2 | Bolt 5/16" x 1" |
| 5 | 71-05 | 18 | Spike Disc | 17 | STD541431 | 2 | Lock nut 5/16" |
| 6 | 71-06 | 30 | Spacer Cup | 18 | 71-18 | 2 | Wheel Mount Bar |
| 7 | 71-07 | 2 | Bushing | 19 | STD541050 | 2 | Hex Nut 1/2" |
| 8 | 71-08 | 2 | Spring | 20 | 71-20 | 2 | Wheel |
| 9 | 71-09 | 2 | Washer | 21 | 71-21 | 2 | stop Pin |
| 10 | 71-10 | 2 | Cotter Pin | 22 | STD511105 | 2 | Bolt 10-32 x 1/2" |
| 11 | STD525025 | 3 | Bolt 1/2" x 2 3/4" | 23 | 71-23 | 2 | Lock Nut 10-32 |
| 12 | STD522507 | 4 | Bolt 1/4" x 3/4" | 24 | STD551050 | 2 | Flat Washer 1/2" |

FULL ONE-YEAR WARRANTY

If this product fails due to a defect in material or workmanship within one year from the date of purchase, Ohio Steel will at its option repair or replace it free of charge. This warranty excludes Tires and Wheels which are expendable and become worn during normal use.

Proof of purchase required.

This warranty does not cover:

- Repairs necessary because of operator abuse or negligence.
- Equipment use for commercial or rental purposes.
- Paint that is worn or faded due to normal use or exposure. Please note that it is a normal occurrence during use and therefore is not covered by this limited warranty.

Contact Ohio Steel to arrange for product repair, or return this product to place of purchase for replacement.

This warranty gives you specific legal rights, and you may also have other rights which vary from state to state. This Warranty applies only while this product is in use in the United States.

SAFETY INSTRUCTIONS

- Pull at low speed - not over 3 M.P.H.
- Do not pull over black top drive unless wheels are locked in the down position.
- Use lowest ground speed when operating on slopes.
- The spike discs on the aerator are sharp.
- Keep all persons a safe distance away
- When operating aerator.
- Always stop the tractor, set brake and
- Remove the ignition key before making any adjustment or repair.
- When storing, position the spikes toward
- The wall or shield them to prevent
- possible injury.

OPERATION

- The weight tray will hold two standard concrete blocks.
- These should be made secure to prevent shifting
- which may cause irregular aeration.
- Approximate weight with blocks - 100 pounds.
- Sand tubes may be used.
- Spikes should be kept clean to allow unit to penetrate soil.
- Oil moving parts regularly for better performance.

Step 1. Stop Pin to the Wheel Mount Bar (18), as shown, using a Pan Head Bolt (22) with Lock Nut (23). BE SURE THE HEADS OF THE BOLTS ARE POSITIONED AS SHOWN. Repeat for other Handle.

Step2. Attach the Side Bar (2) to the Weight Tray (1) using two bolts (12), add lock nuts (14) to secure.

Repeat above procedure for the other side.

Sub-assemble the Hitch Brackets (3), as shown, with two bolts (16), add lock nuts (17) to secure.

Position Hitch Assembly between the ends of the Side Bars. Use the bolt (11) with lock nut (13). DO NOT OVER TIGHTEN. Hitch should swivel.

MAINTENANCE / STORAGE

- Periodically check all nuts and bolts for tightness.
- Lightly oil all exposed metal parts to prevent rust.
- Keep Unit clean and dry to prevent rust and corrosion.
- Store inside a clean, dry area
- when not in use.

TOOLS REQUIRED

3/8" Wrench and / or Socket
 7/16" Wrench and / or Socket.
 1/2" Wrench and / or Socket.
 3/4" Wrench and / or Socket.
 Pliers
 Screwdriver

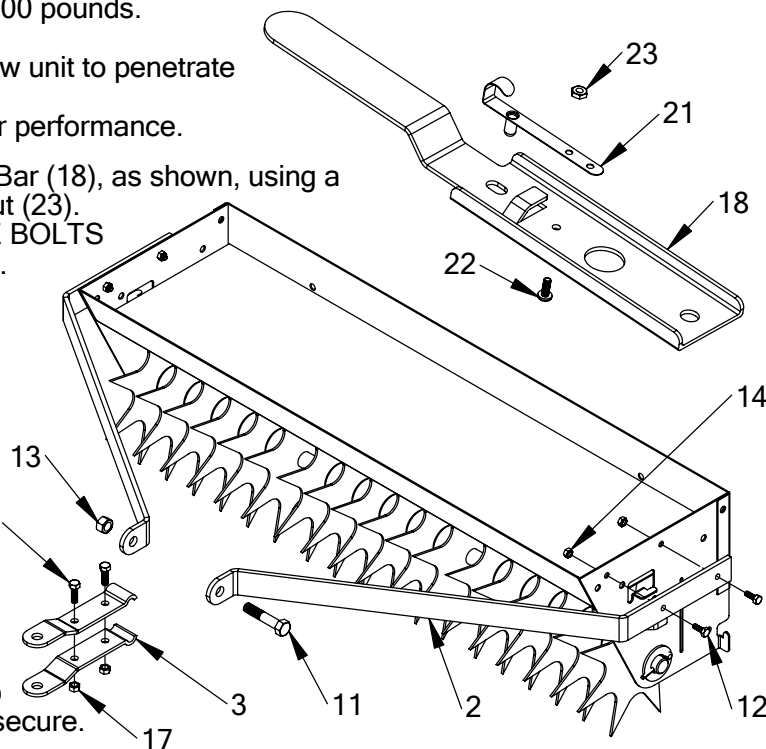

CAUTION

BE EXTREMELY CAREFUL ASSEMBLING AERATOR, AS SPIKES ARE VERY SHARP, ANY KIND OF CONTACT COULD CAUSE SERIOUS INJURY.

Step3. To add the Wheel Mount Bar (18), stand Aerator on its end making sure to avoid spikes by working on opposite side and facing the spikes towards a wall whenever possible in case of accidental fall. Remove Cotter Pin (10).

NOTE: THIS CAN BE ACCOMPLISHED EASIER BY APPLYING PRESSURE TO THE WASHER WHILE STANDING UNIT ON ITS AXLE.

Add Wheel Mount Bar over Axle (4) as shown, add the Washer (9) and secure with Cotter Pin (10) previously removed.

DO NOT ADD WHEEL AT THIS TIME. Turn unit over on its other end and repeat above procedure.

After Wheel Mount Bars have been added, lay Aerator back on its spikes.

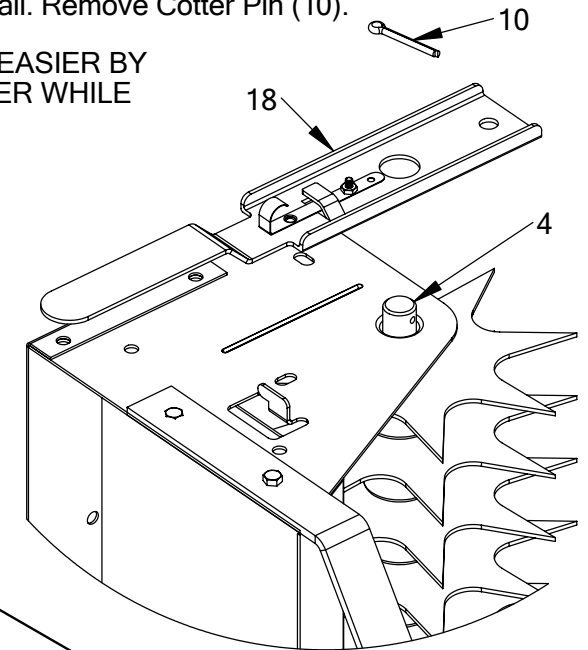

Step4. To add the Wheels (20), insert Bolt (11) through Wheel, Washer (24) and tighten snug with 1/2" Hex Nut (19). Insert this assembly through Wheel Mount Bar (18) and secure with 1/2" Lock Nut (13).

Make appropriate adjustments to Hex Nut (19) so that wheel moves freely without any wobble.

